

FIG. 1

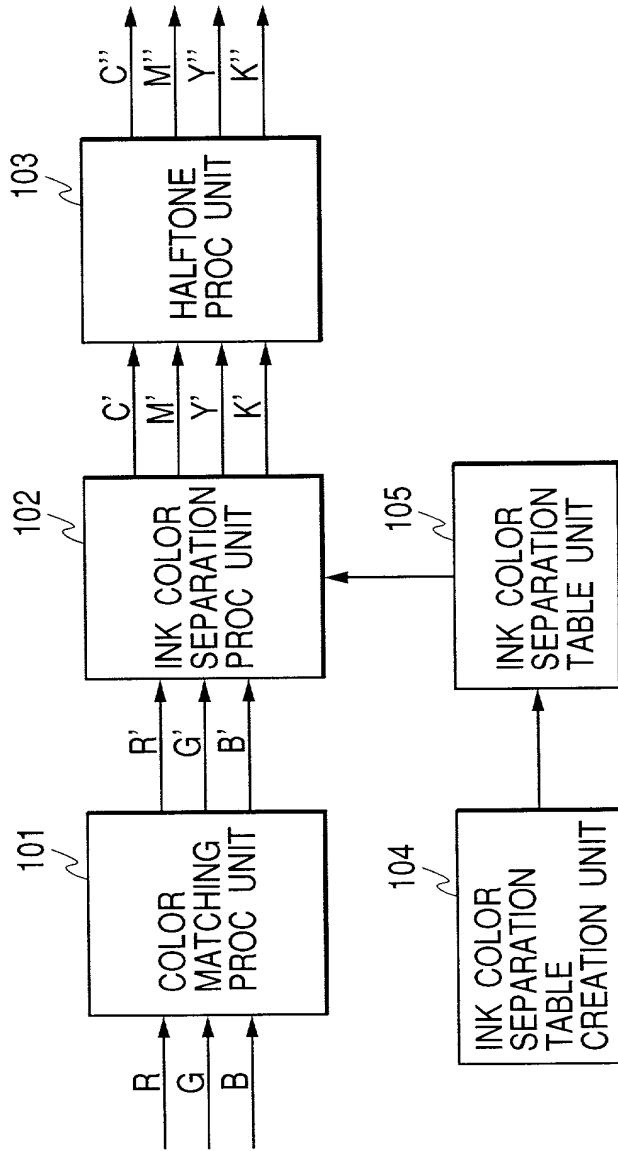

FIG. 2A

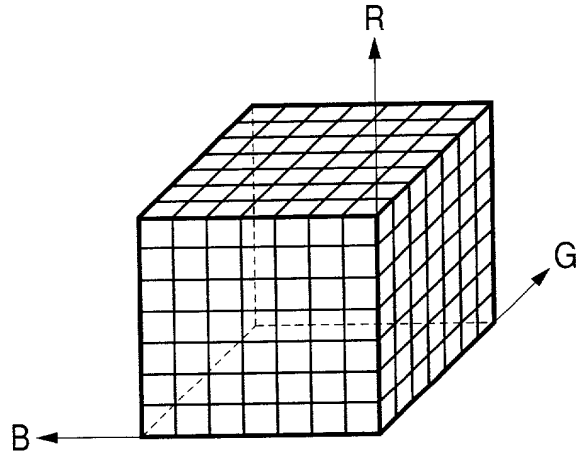

FIG. 2B

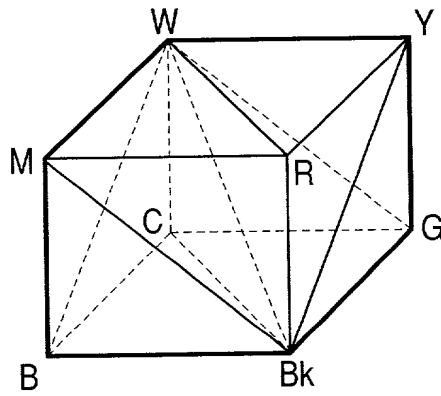

FIG. 2C

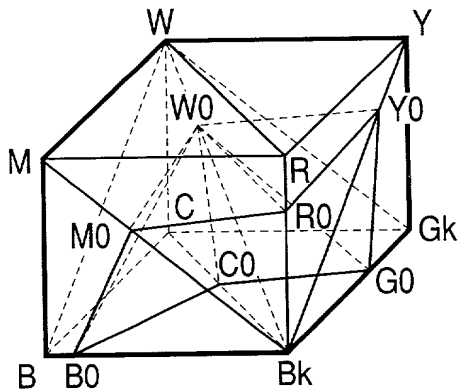
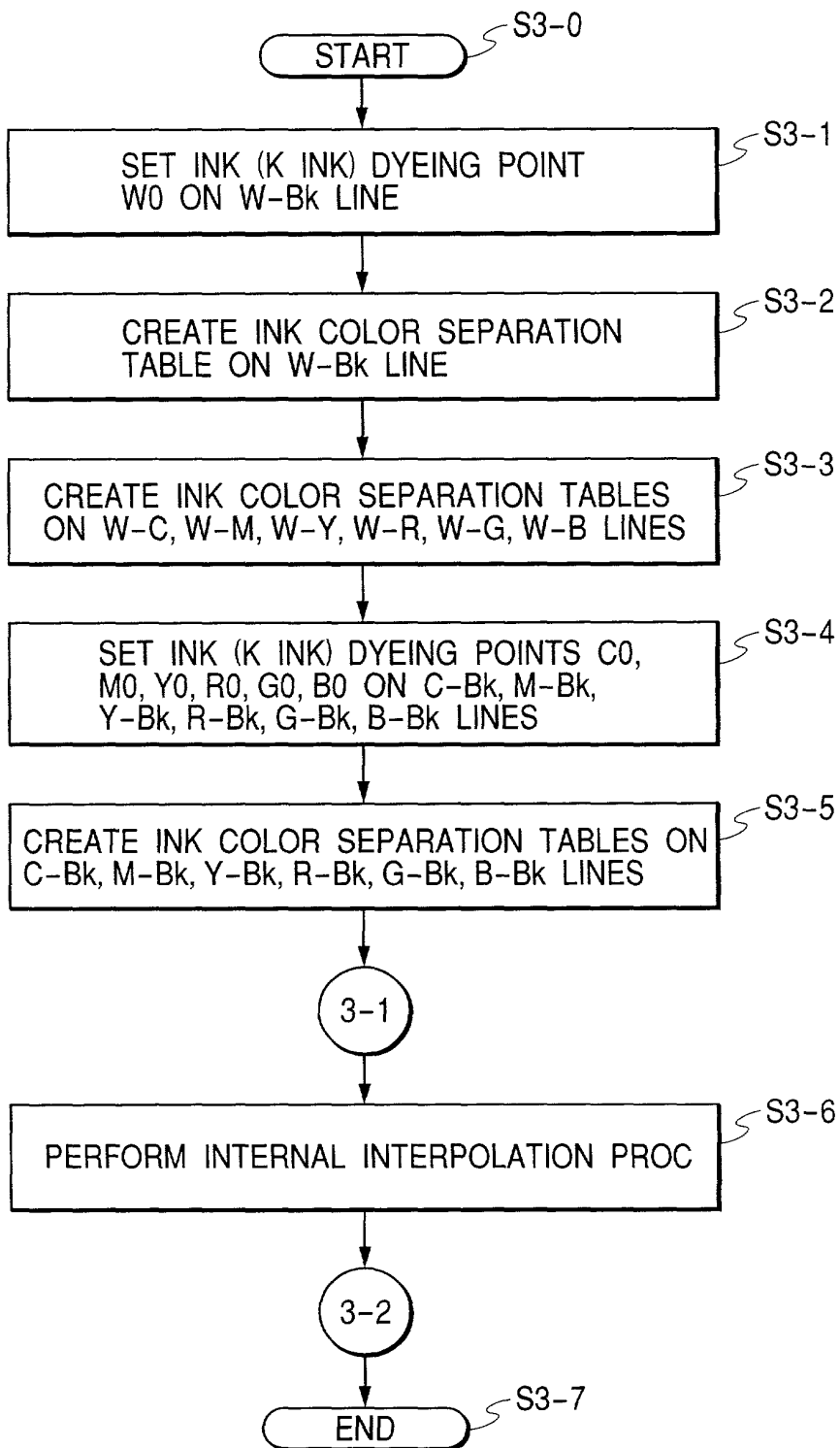
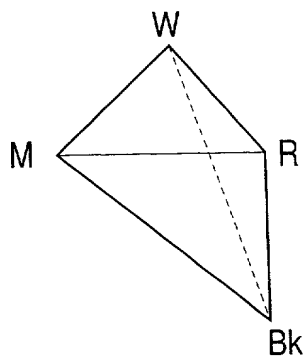

FIG. 3



**FIG. 4A**



**FIG. 4D**

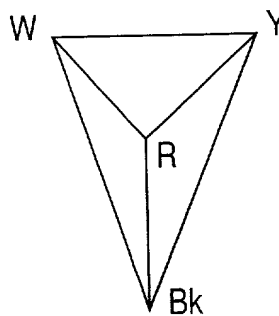

**FIG. 4B**

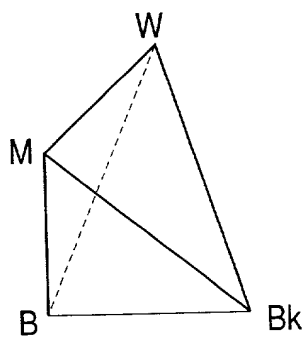

**FIG. 4E**

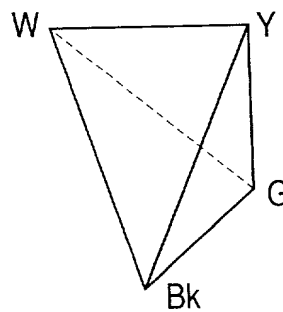

**FIG. 4C**

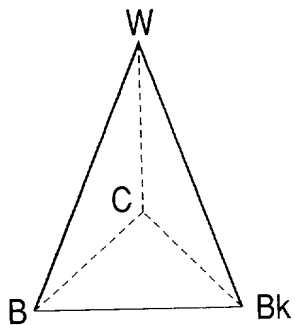

**FIG. 4F**

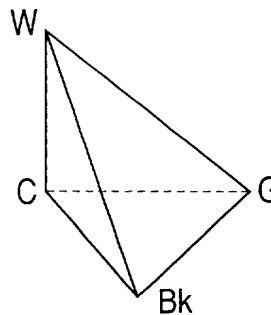
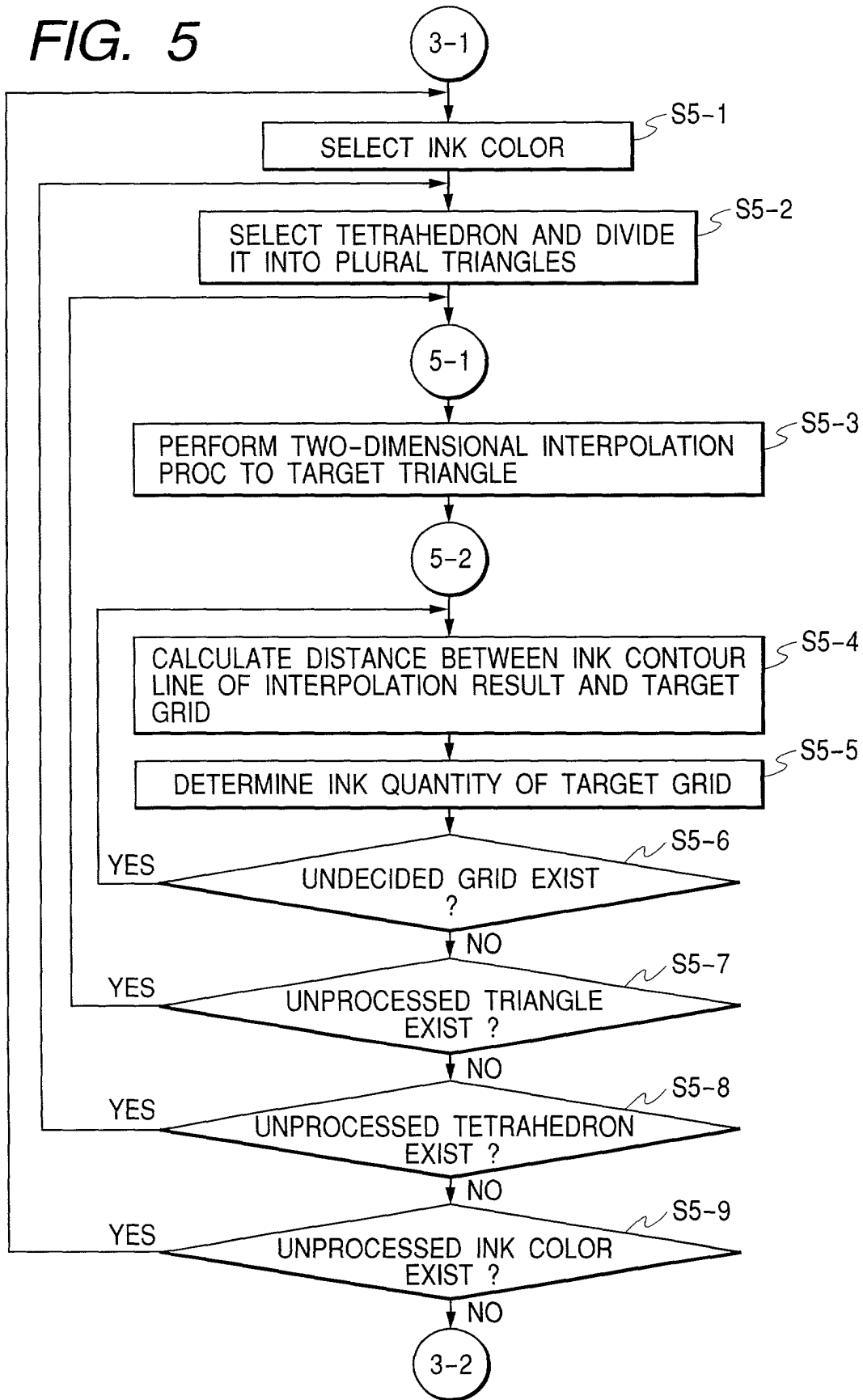

FIG. 4A

FIG. 5



Patent of 2000

FIG. 6

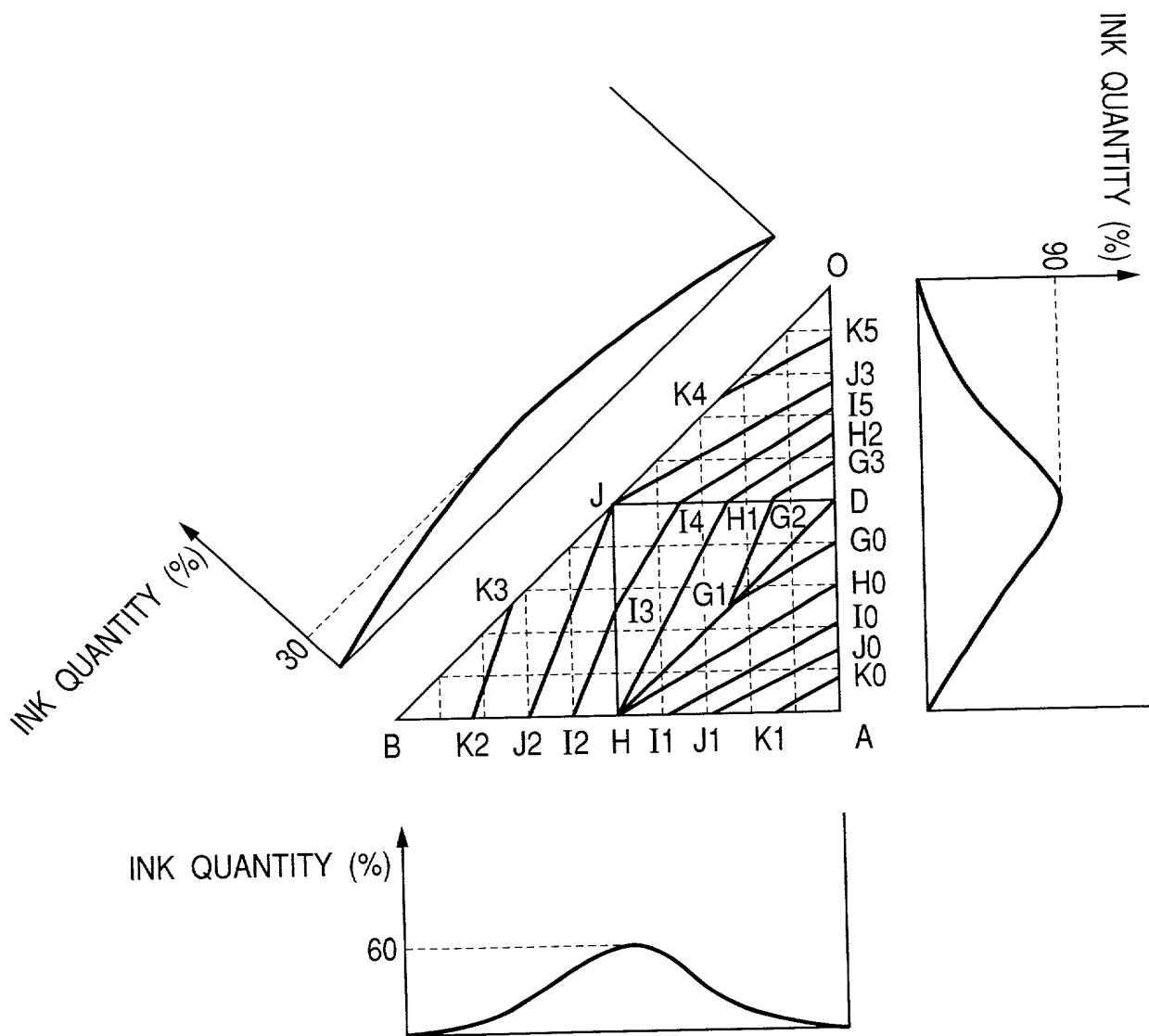
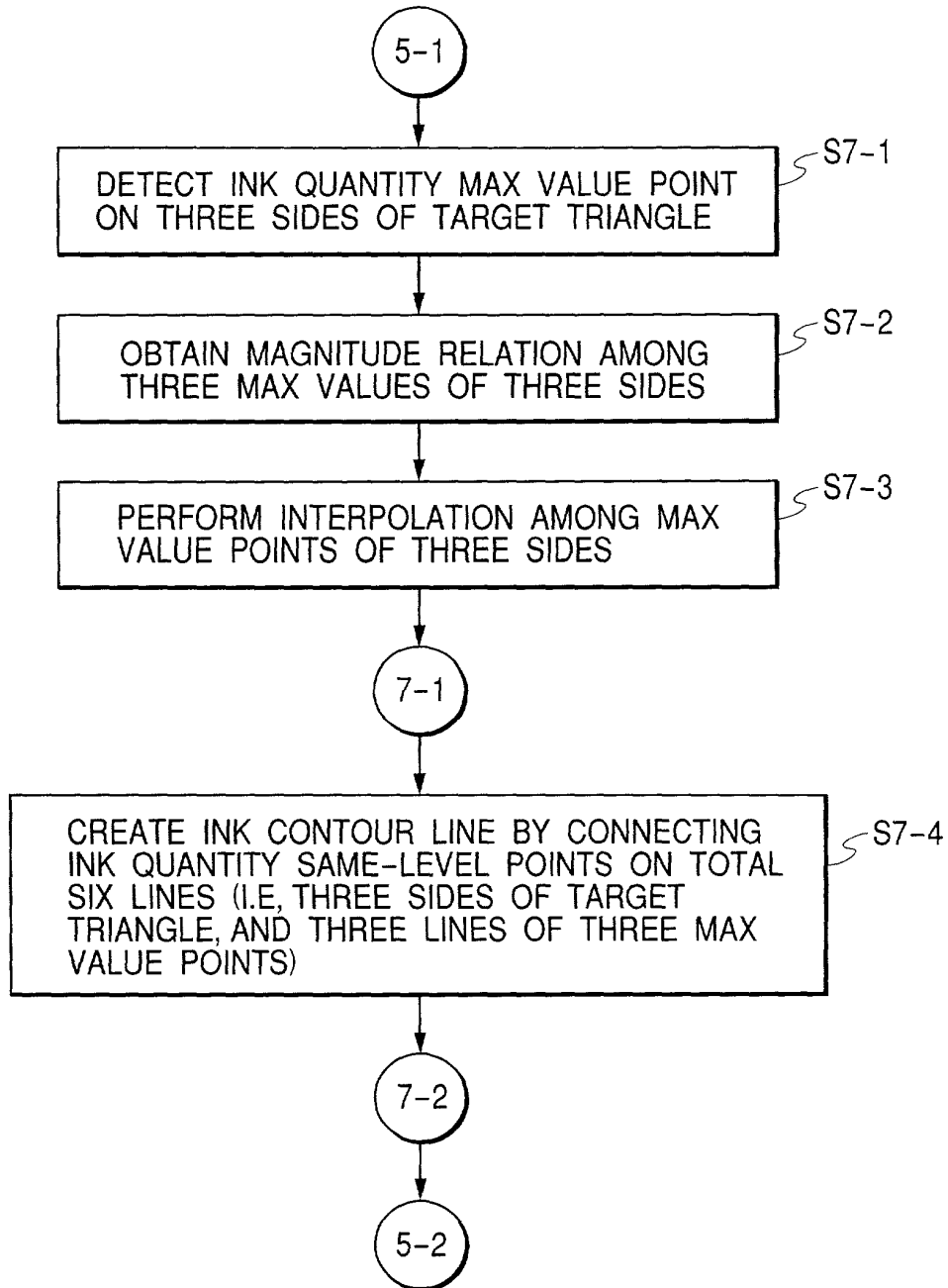
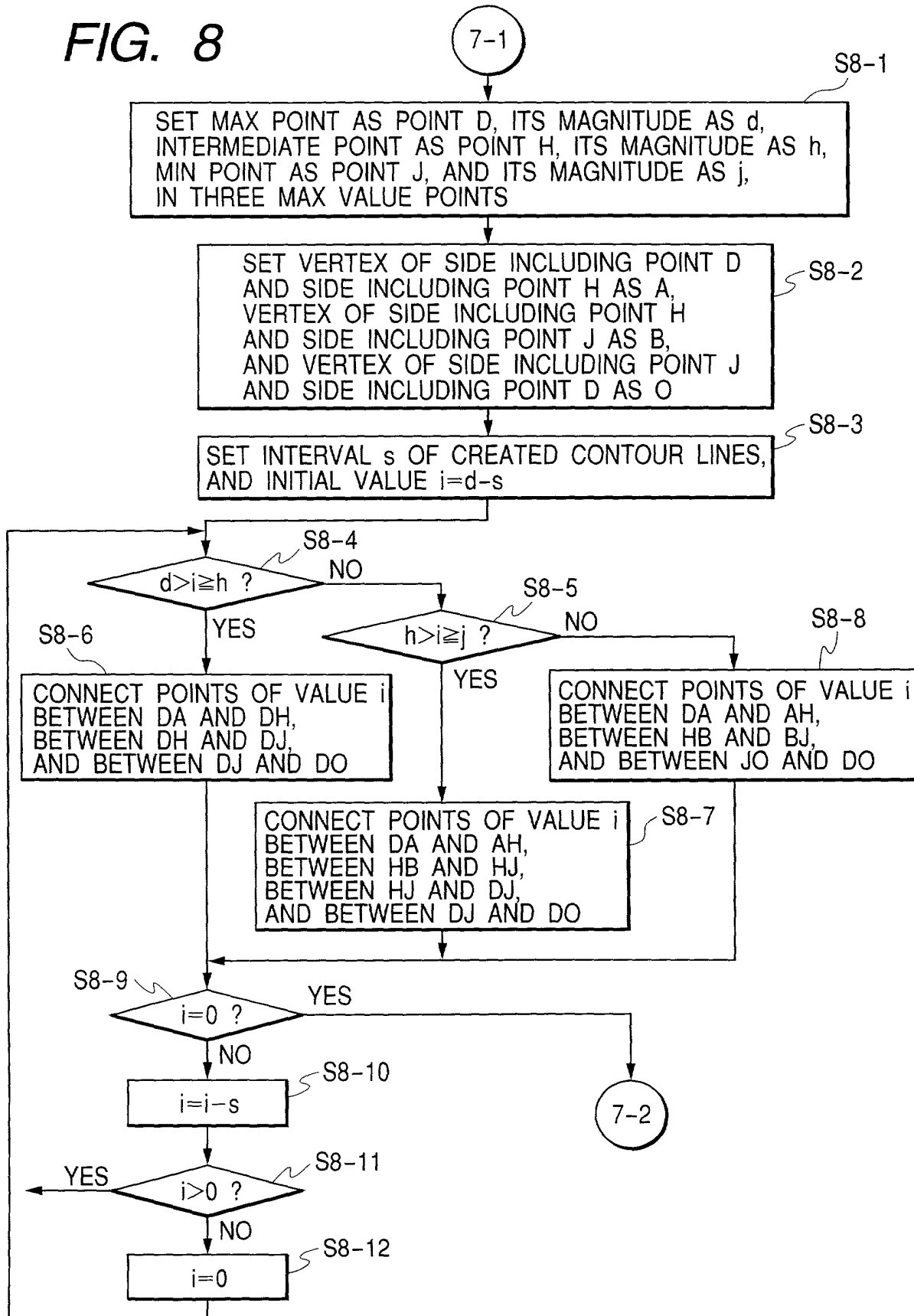

FIG. 7



FOR OFFICIAL USE ONLY

FIG. 8



TOP SECRET



FIG. 9

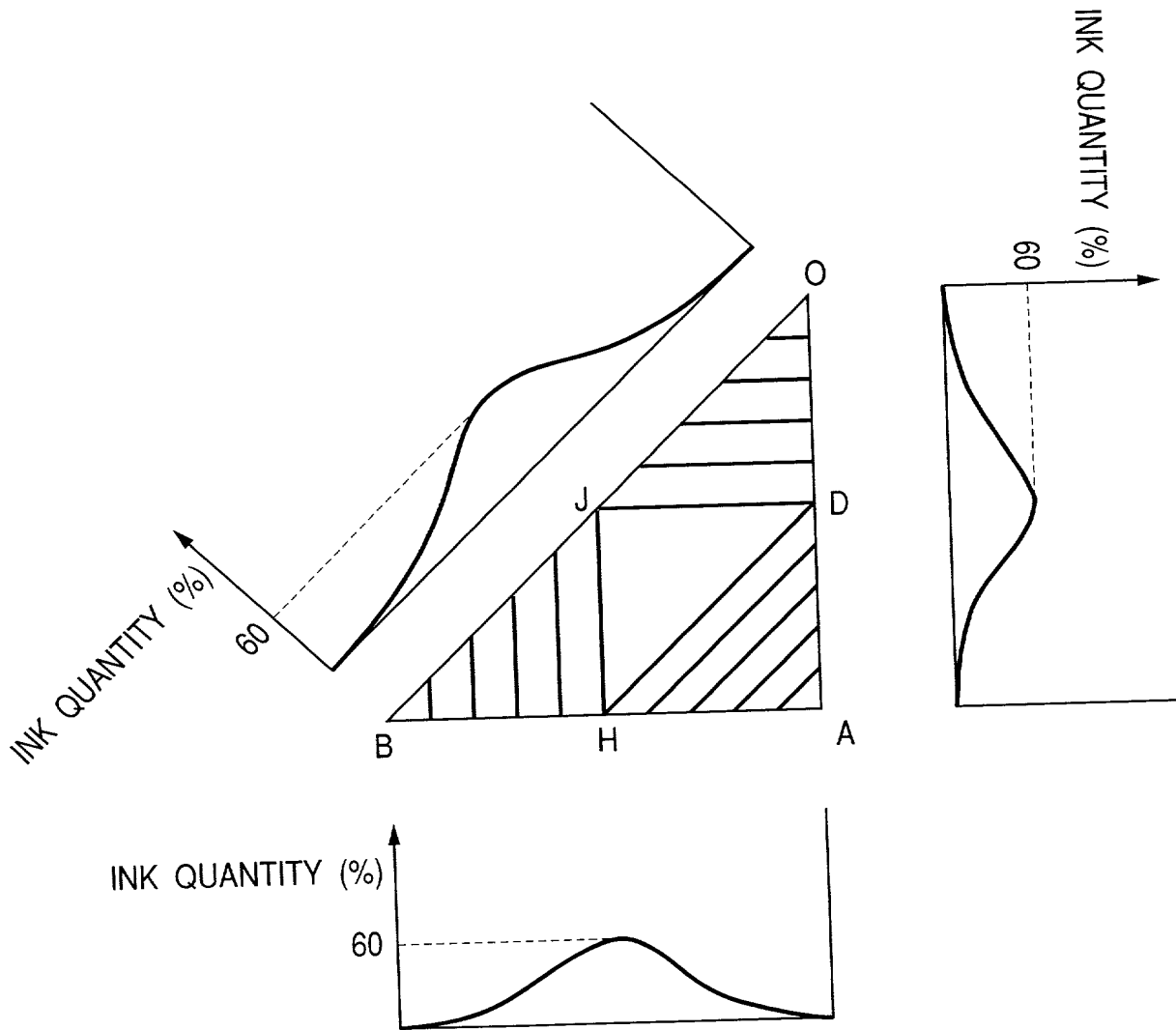

FIG. 10

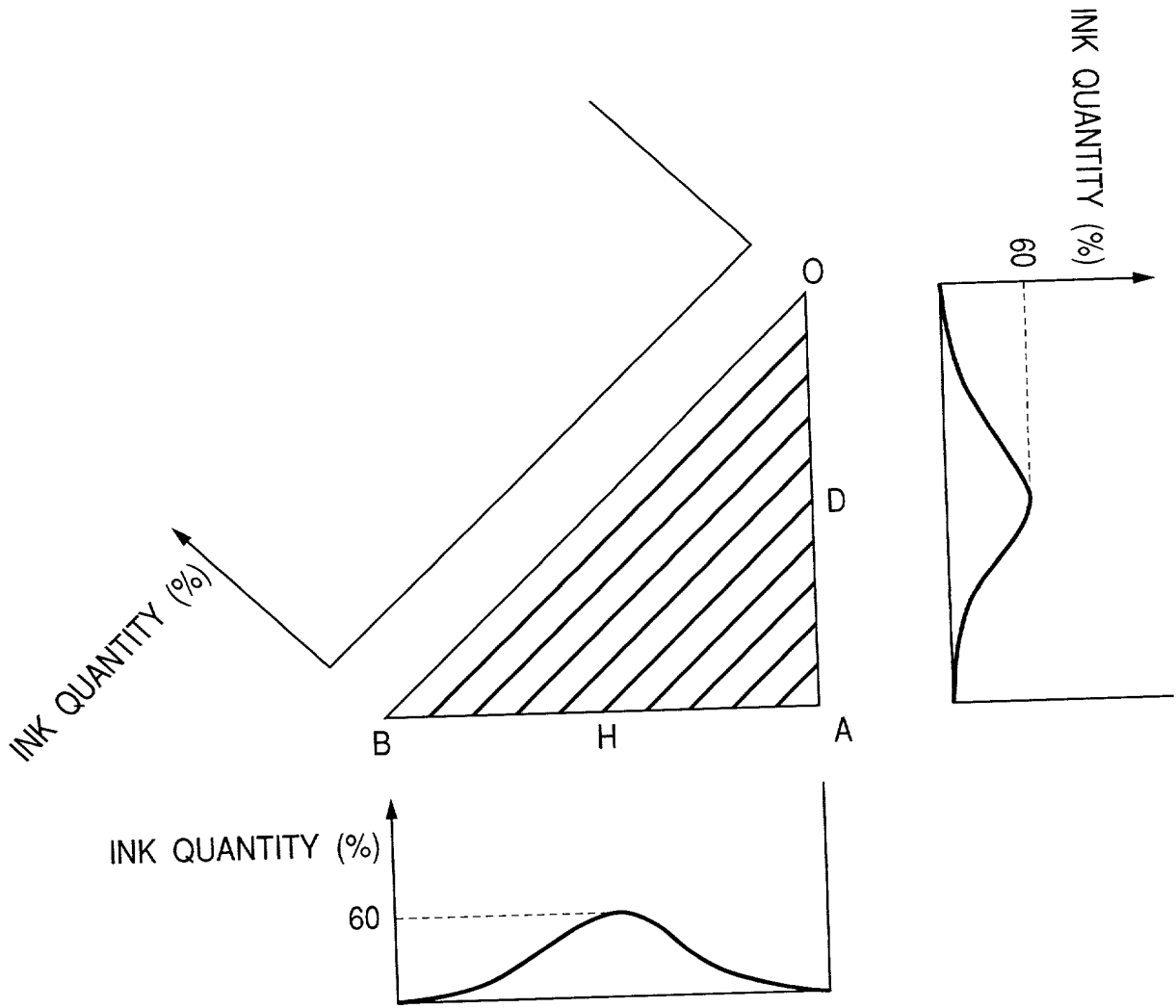

FIG. 11

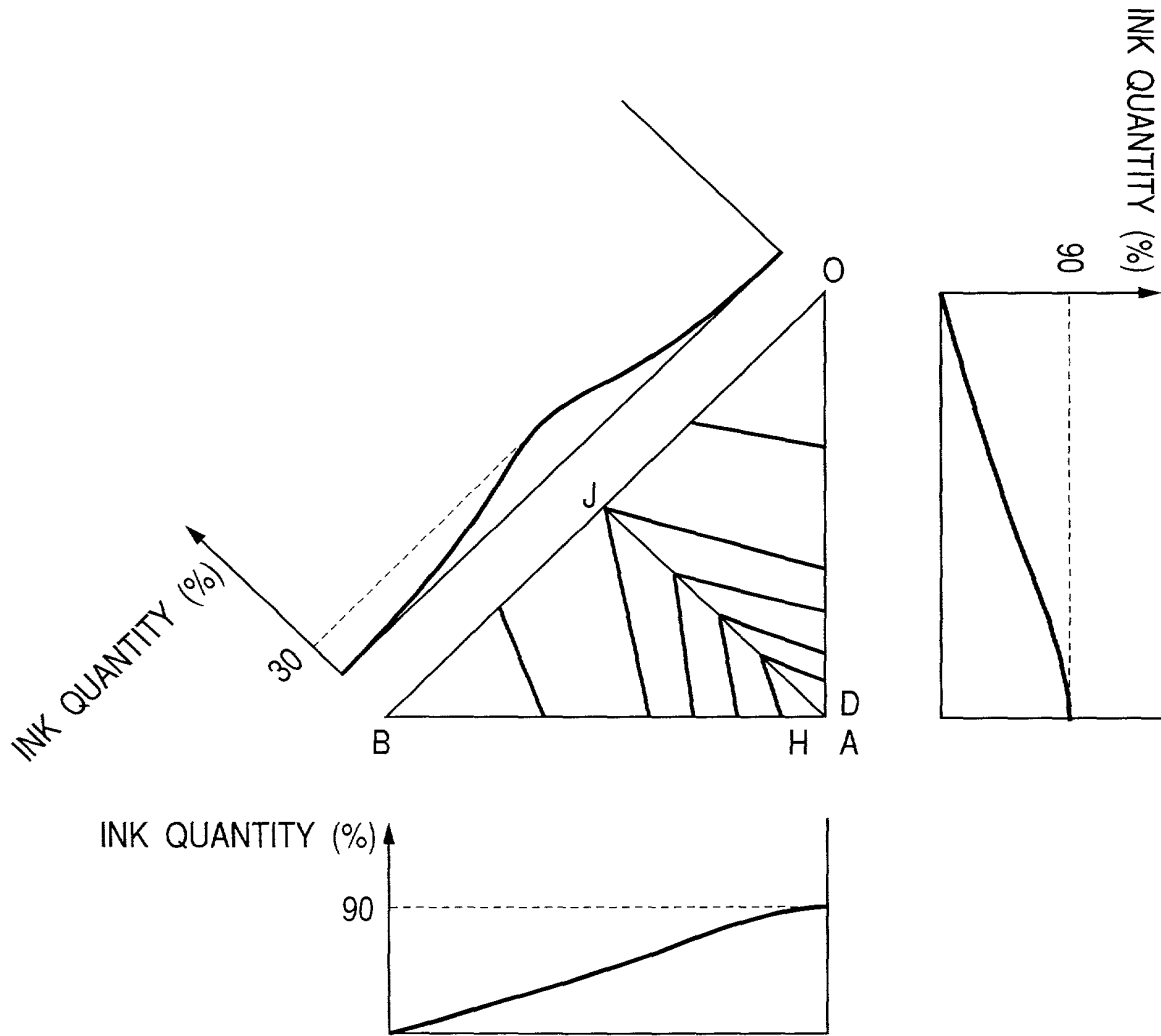
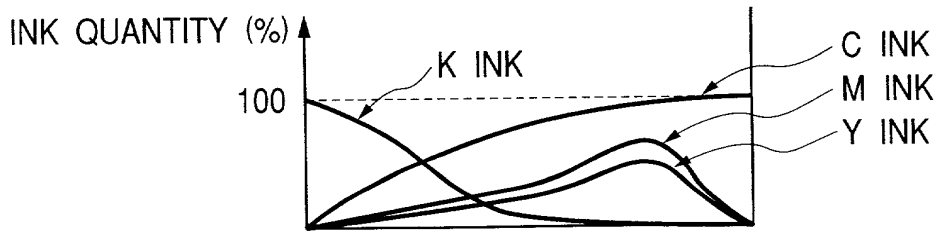
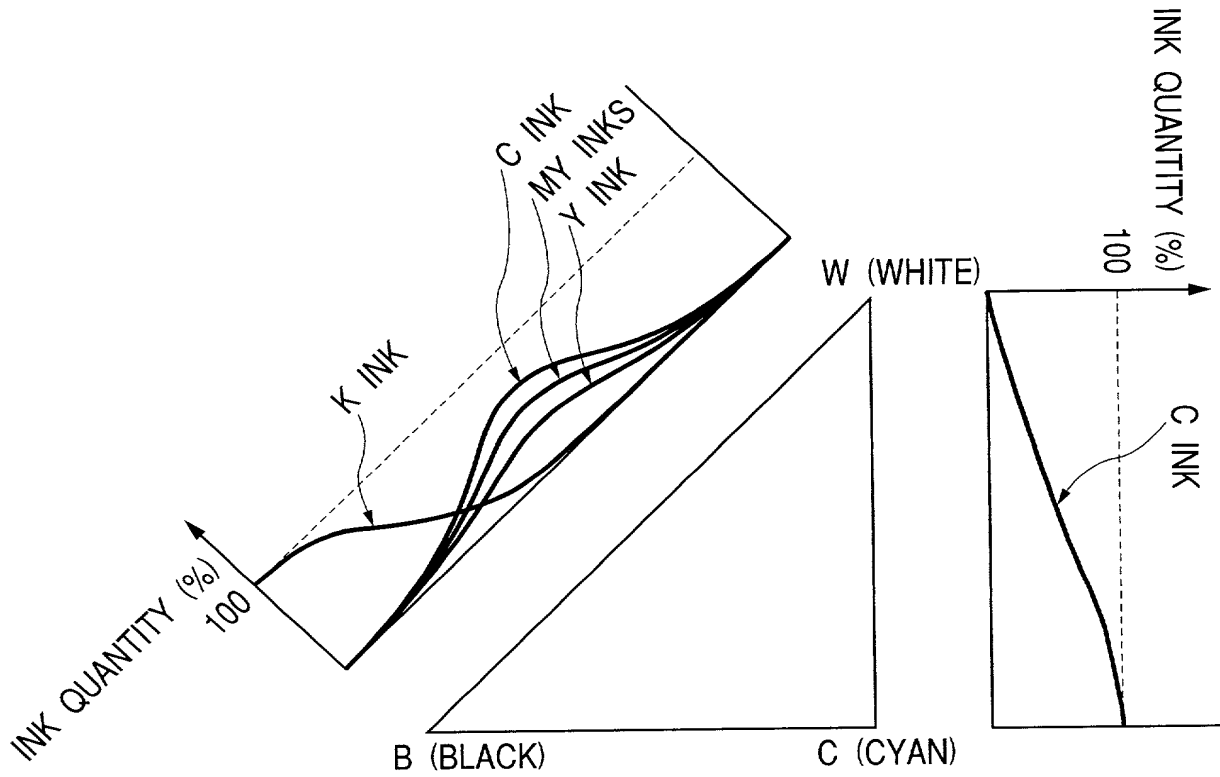
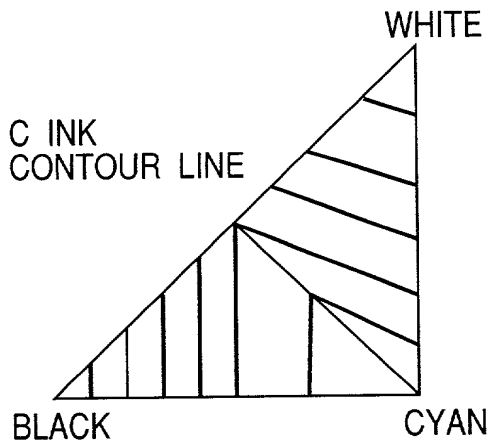

FIG. 12



**FIG. 13A**



**FIG. 13B**

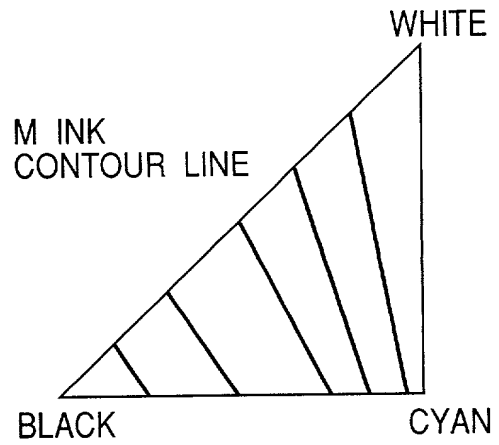

**FIG. 13C**

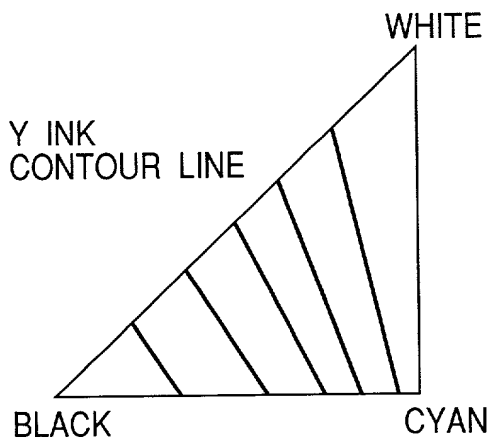

**FIG. 13D**

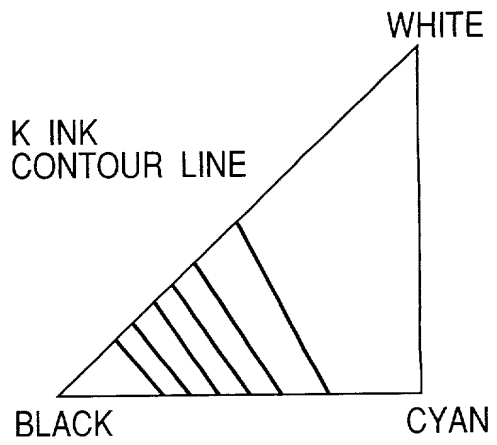

FIG. 13A

FIG. 14

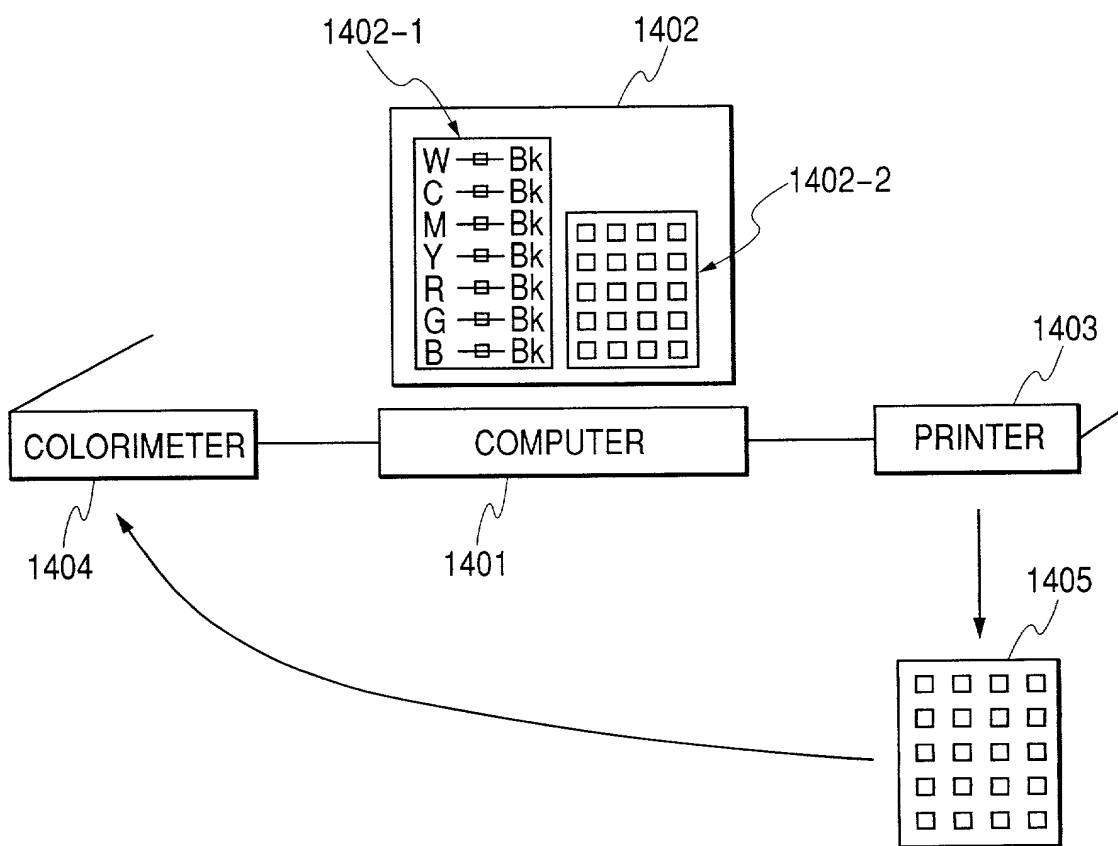

FIG. 14

FIG. 15

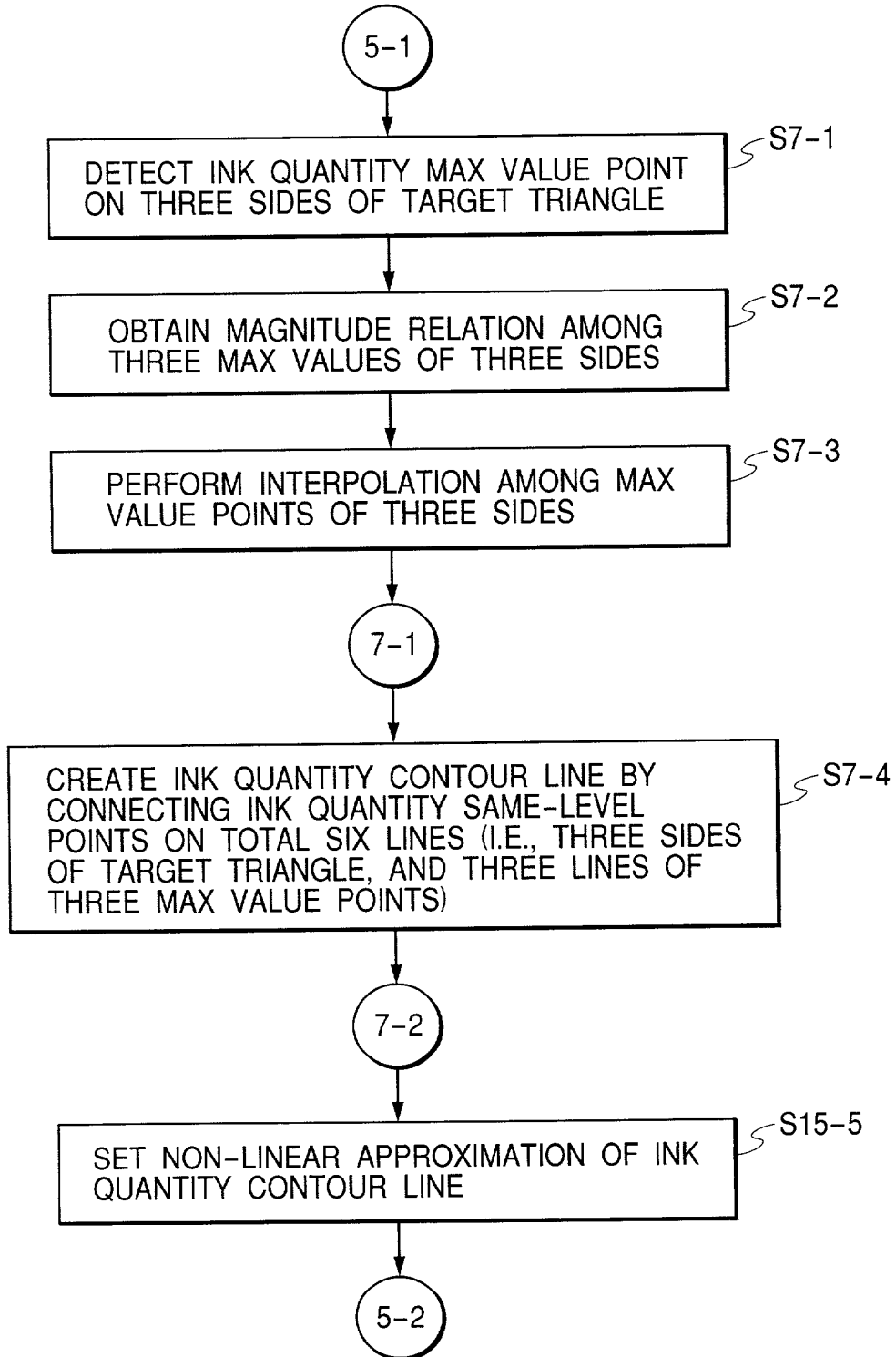
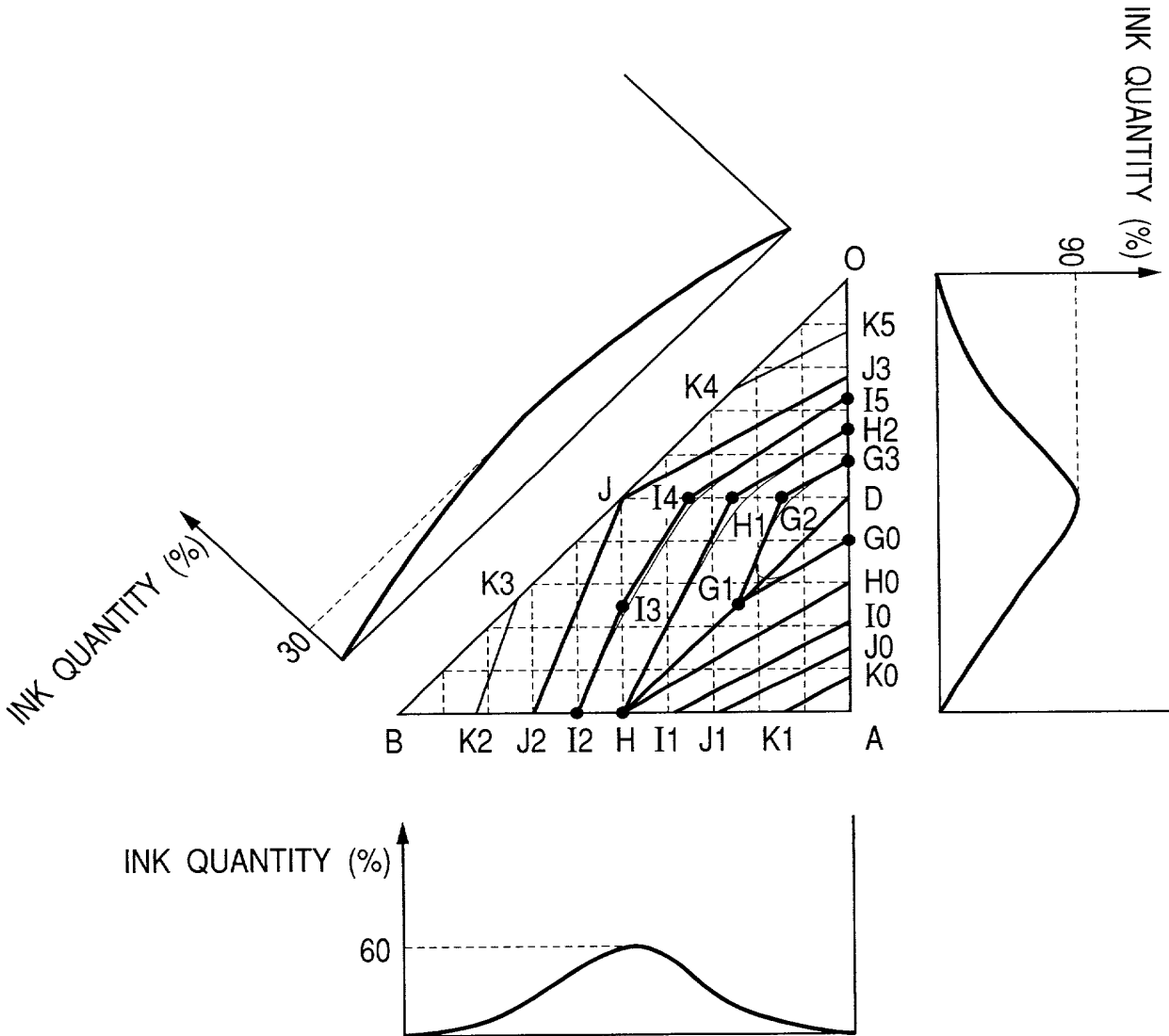

FIG. 15

# FIG. 16



6110066



FIG. 17

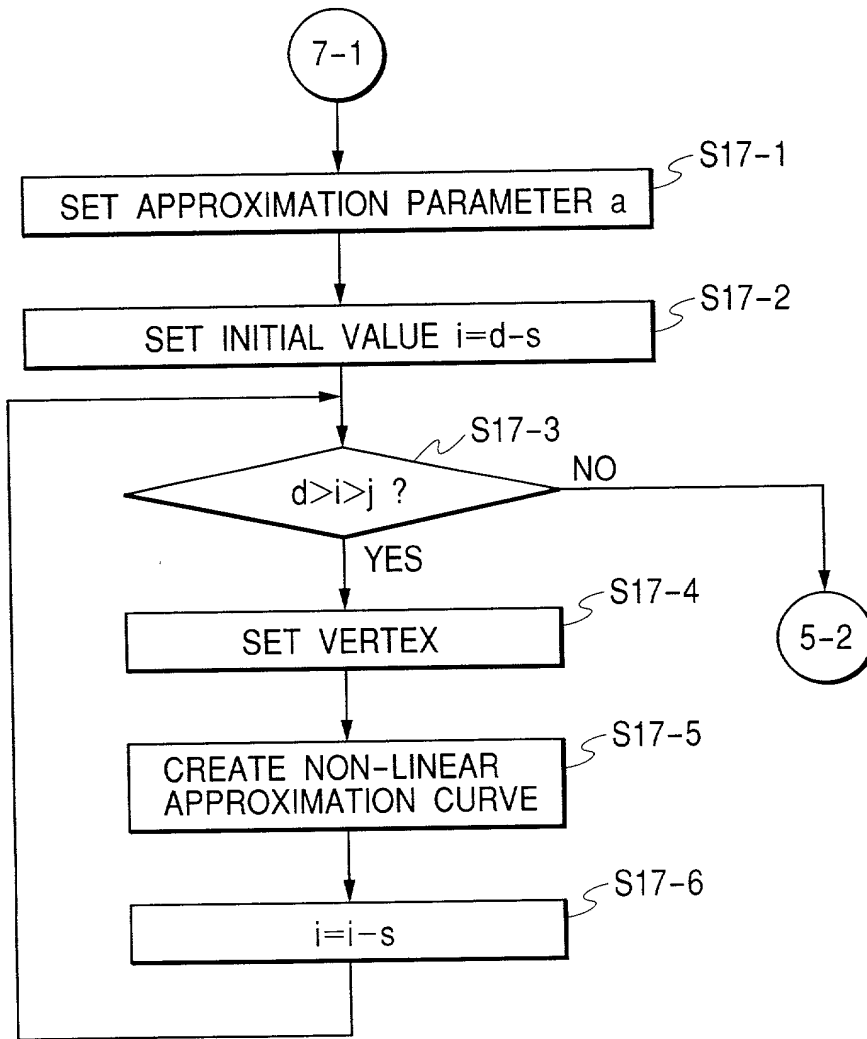

FIG. 17

FIG. 18

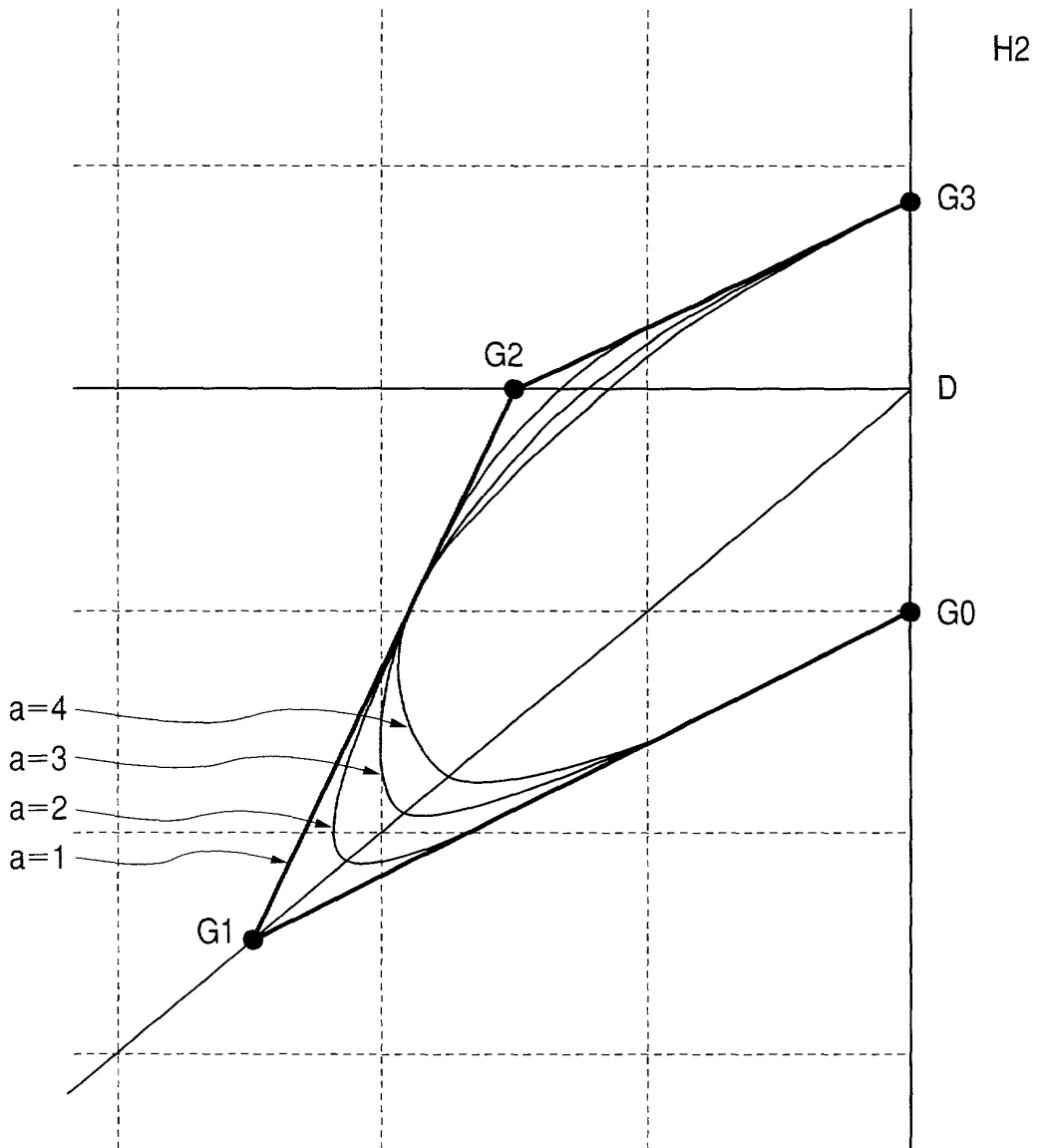

FIG. 18

FIG. 19

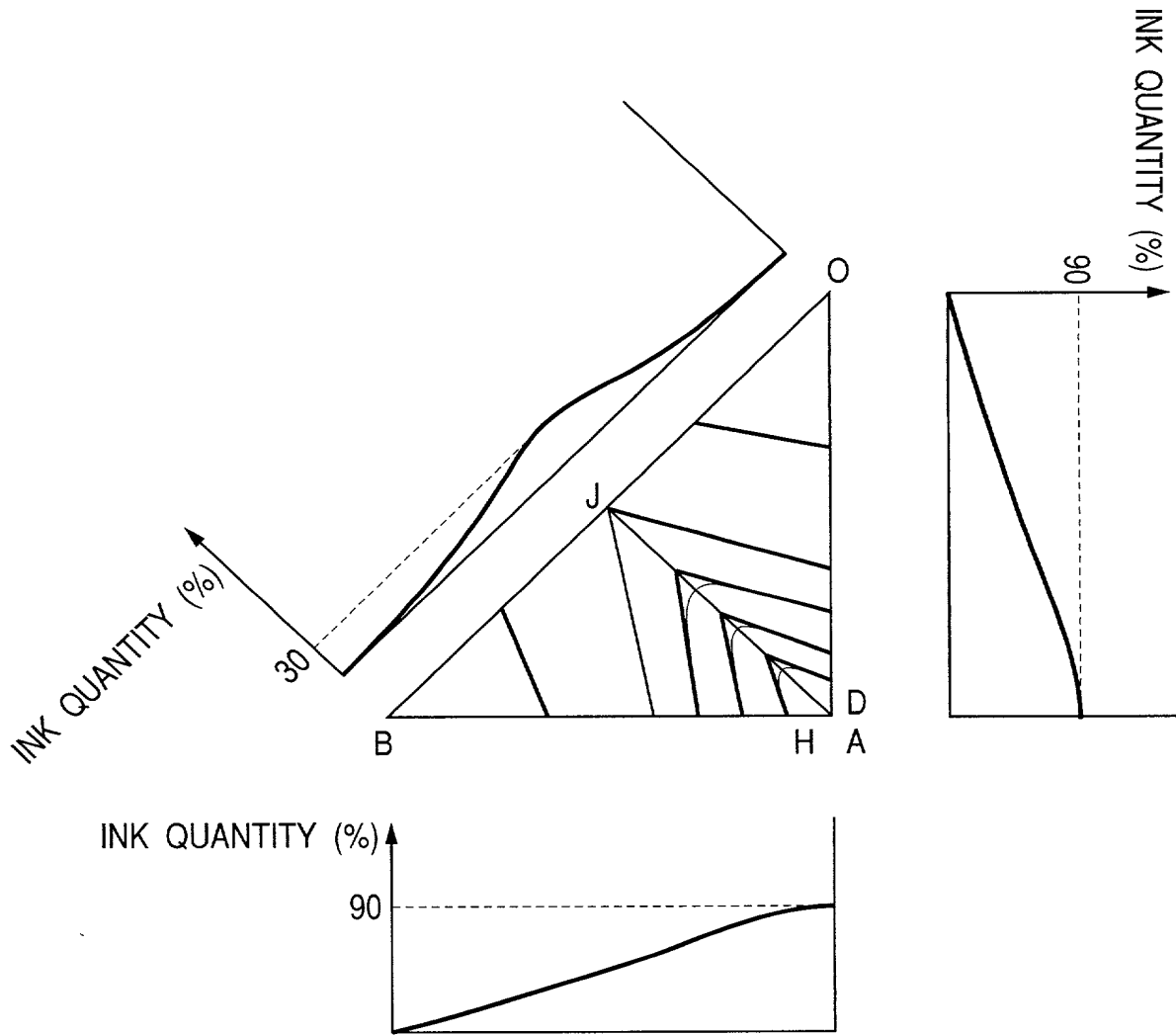
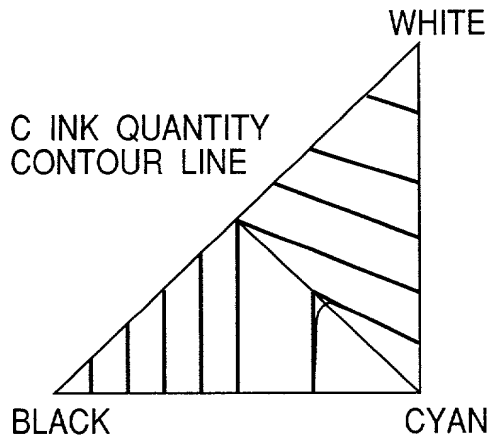
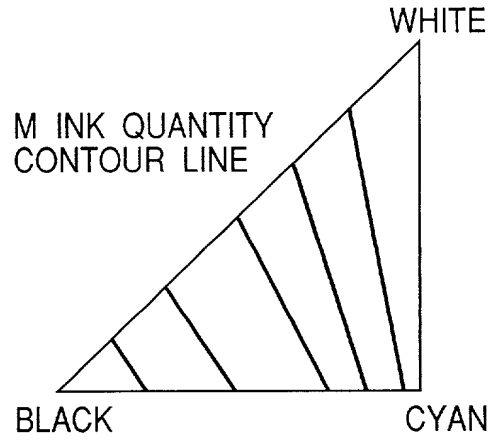

FIG. 19

**FIG. 20A**



**FIG. 20B**



**FIG. 20C**

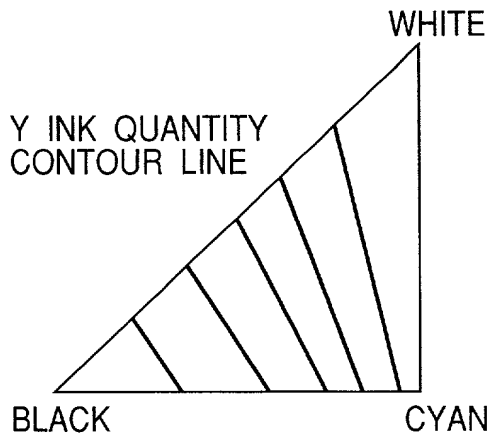

**FIG. 20D**

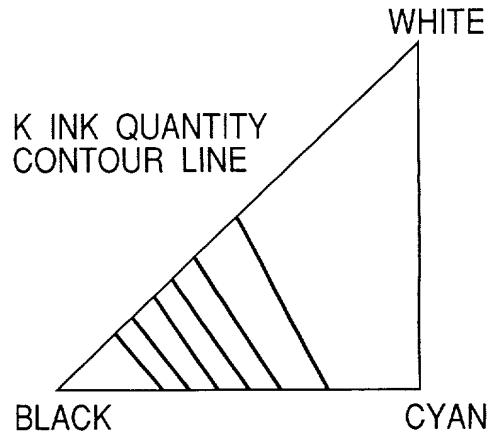
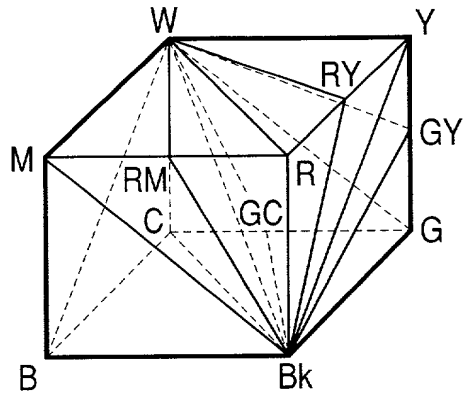
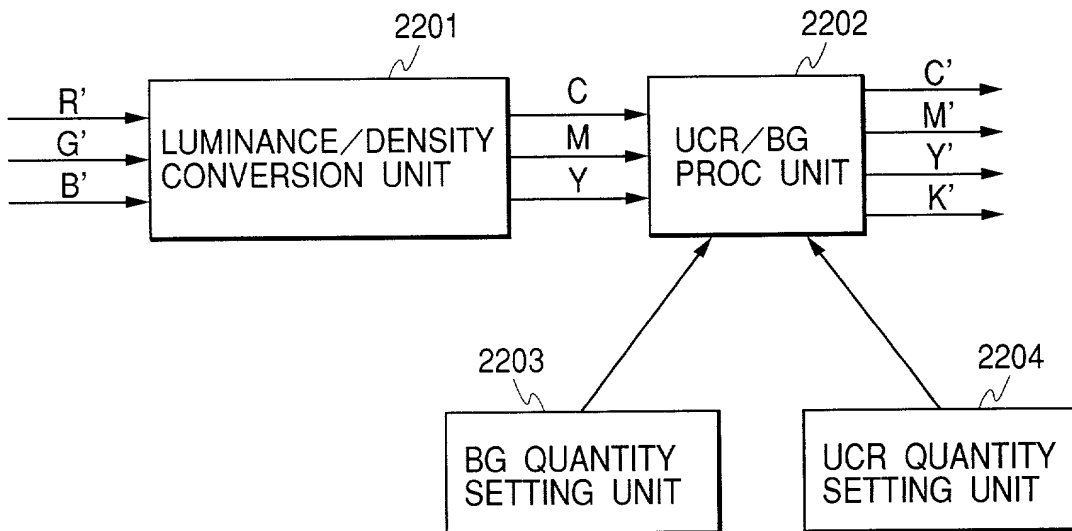

FIG. 20A

**FIG. 21**



**FIG. 22**



www.konica.com